

COMPACT

#3

30141

NEW

EJECTOR ACCELERATOR

∅ 3-8 mm

- › Enables additional ejector stroke (max 7.6 mm)
- › Process reliability for part demoulding
- › Optimised for ejector base plates in thicknesses of 17 mm, 22 mm and 27 mm
- › Can also be used in combination with support plates (thickness 4 mm) – type 2



OPTIMISED FOR
PLATE THICKNESS
17, 22 AND
27 MM

300112 • 300112DLC • 300113 • 300113DLC

NEW

SPRUE HOLDING PIN

300112

∅ 3-12 mm

- › Undercut holds sprue manifold in position
- › Enables controlled removal
- › Supplied ready for installation
- › Contour can be used for many plastics
- › Short production/delivery time
- › Engraving optional
- › CAD data available online
- › Hardened version optionally with DLC coating



496045 • 496046

NEW

TRANSPORT LOCK FOR EJECTOR SET – STAINLESS STEEL

496046

SUITABLE FOR
CLEANROOM

- › Simple and space-saving assembly
- › Locks the ejector set
- › Prevents damage to contour ejector pins
- › Minimises risk of injury



496045

EJECTOR PIN FOR VENTING

- › Tool optimisation by venting the cavity
- › Self-cleaning and high-precision helix geometry ensures reliable operation
- › Less punctual surface wear increases service life
- › Interchangeable with standard ejector pins
- › Wide range of dimensions ($\varnothing 2$ to $\varnothing 12$ mm)
- › Hardened version optionally available with DLC-coating

\varnothing 2-12 mm
|| 125-450 mm

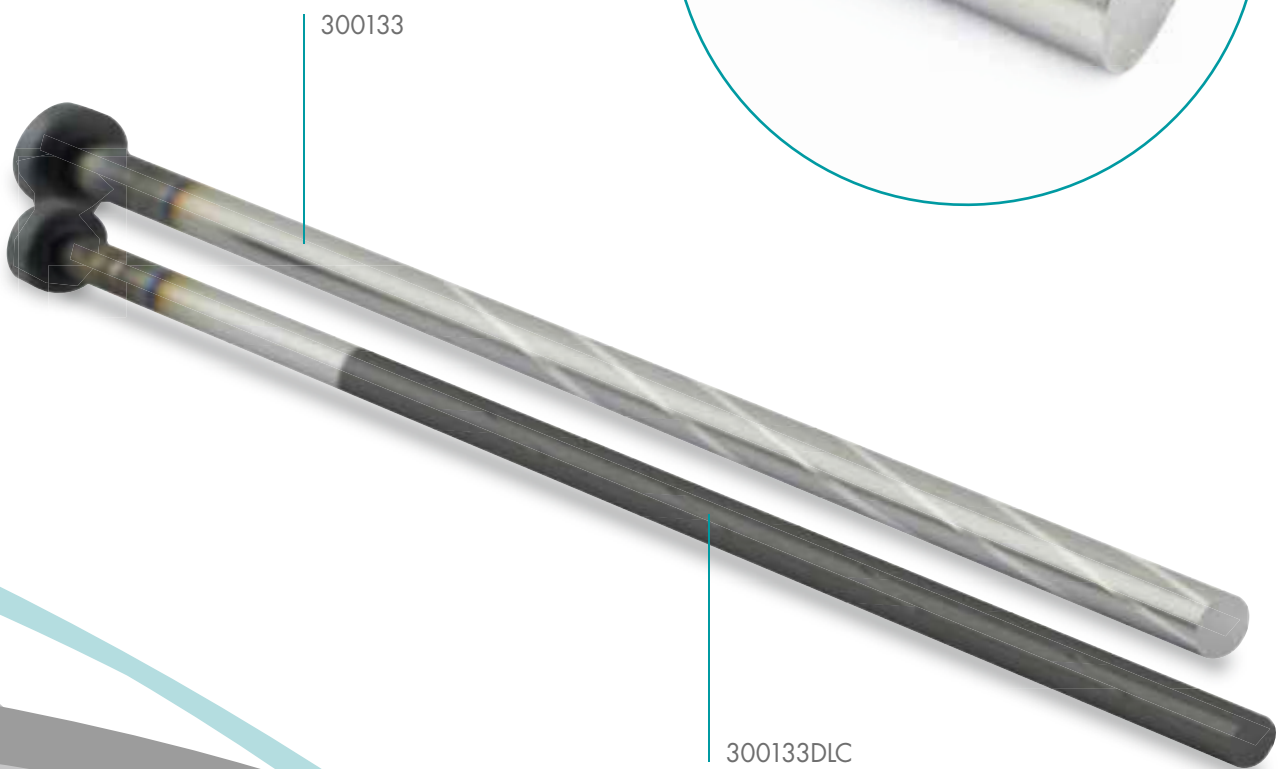

SLIDE RAILS SELF-LUBRICATING

40-315 mm

- › Self-lubricating version – no additional greasing necessary
- › Various lengths and designs
- › Flexibel delivery due to high stock availability

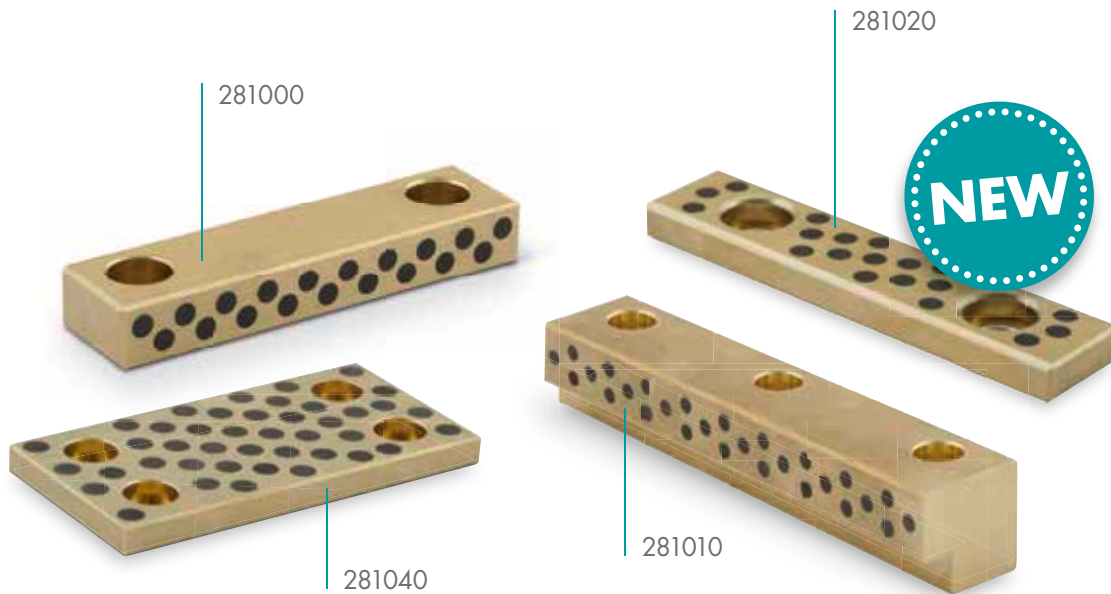

51300

POSITIONING WEDGES

80-160 mm

30-100 mm

- › Positioning and fixing of the mould insert
- › Facilitates assembly and disassembly of the mould insert
- › One or two extraction threads (depending on length)

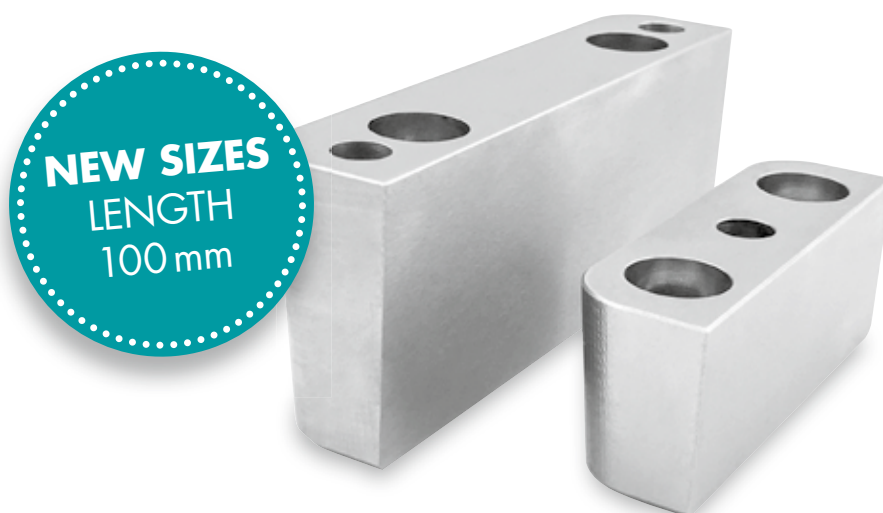

SLIDE RAILS WITH DLC-COATING

- Optimal gliding and dry-run properties achieved by DLC-coating
- Additional oil-grooves
- Various standard lengths available
- Can be shortened to the individually desired length
- Flexibel delivery due to high stock availability

48-398 mm



283045

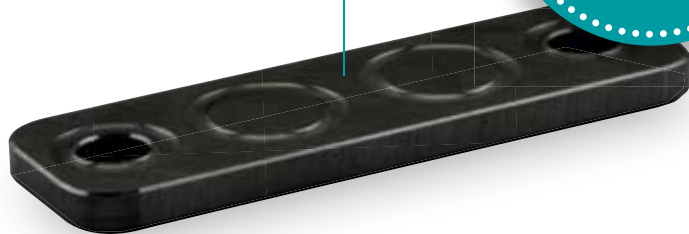

282530



282500

285000

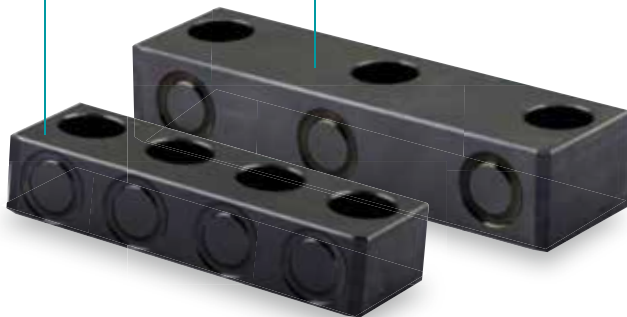

285040



282520

282540

282510

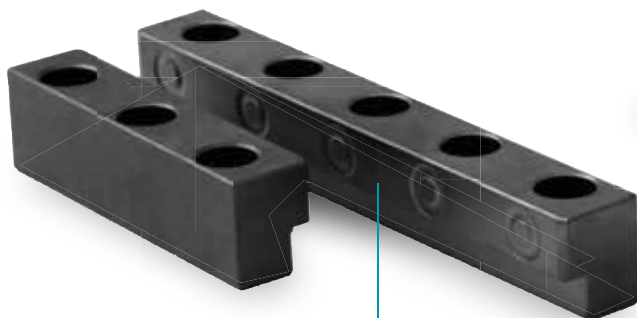

ORDER ONLINE
KNARR WEBSHOP



3D CONFIGURATOR
ACCORDING TO YOUR
REQUIREMENTS



CAD DOWNLOAD
FOR ALL STANDARD PARTS
AND PLATES



DASHBOARD
OVERVIEW OF RELEVANT
INFORMATION

START NOW
Shop.KNARR.com

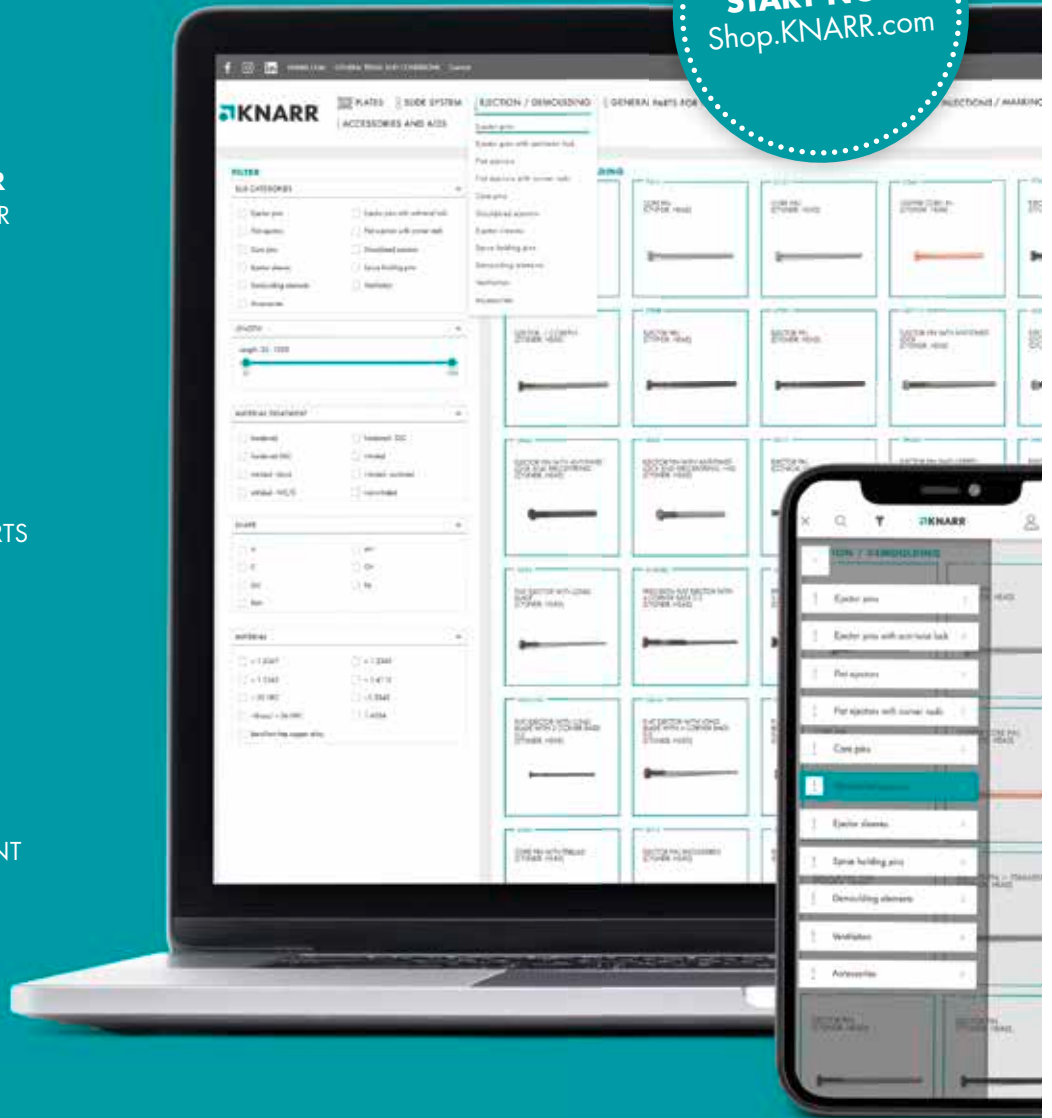

KNARR VERTRIEBS GMBH

Gunterstraße 31
95233 Helmbrechts
Germany

Telefon +49 9252 9993-500
Fax +49 9252 9993-33
E-Mail sales@knarr.com

Misprint, price and product changes are reserved.
You can find our general terms and conditions on our website – www.knarr.com
EN – 05/2023