

WYMIARY ZEWNĘTRZNE · VNĚJŠÍ ROZMĚRY

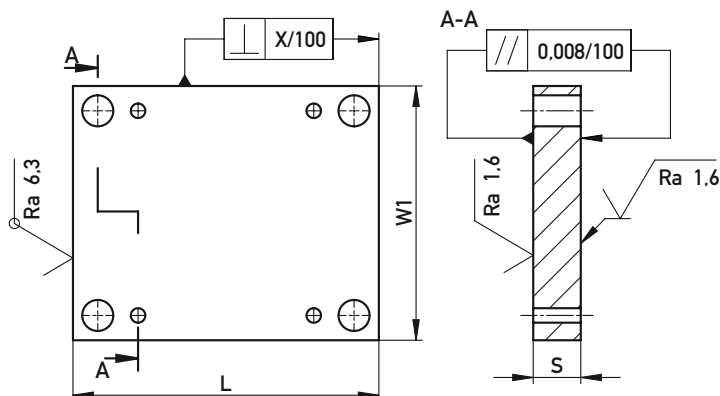

Materiál Material	Numer produktu Č. výrobku	L	W1	S	X/100
1.1730 1.2085 1.2312 Toolox® 33 1.2738	inne ostatní	± 0,15	± 0,15	+ 0,25 + 0,1	0,02
	10020	+ 0,5	+ 0,5	+ 0,25	0,02
	10030	+ 0,2	+ 0,2	+ 0,1	
	15500				
	15600				
1.2343 1.2767	wszystkie vše	+ 0,5 + 0,3	+ 0,5 + 0,3	+ 0,6 + 0,4	0,04

OBRÁBKVA PRECIZYJNA (10020 / 10030 / 15500 / 15600)

PŘESNÉ OBRÁBĚNÍ (10020 / 10030 / 15500 / 15600)

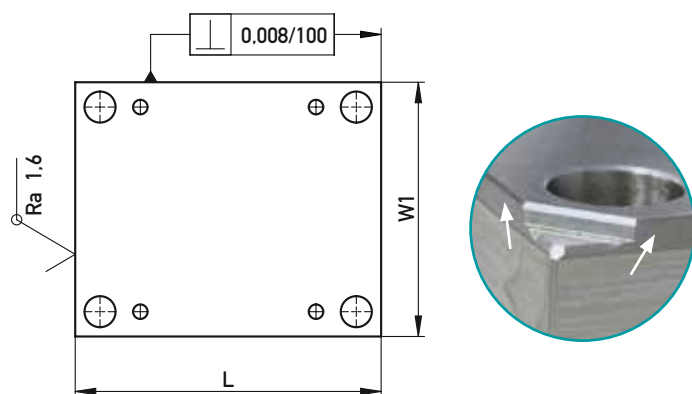

Materiál Material	L	W1
1.1730 1.2085 1.2312 Toolox® 33	± 0,02	± 0,02

OTWORY NA ŚRUBY · VRTÁNÍ SE ZÁVITEM

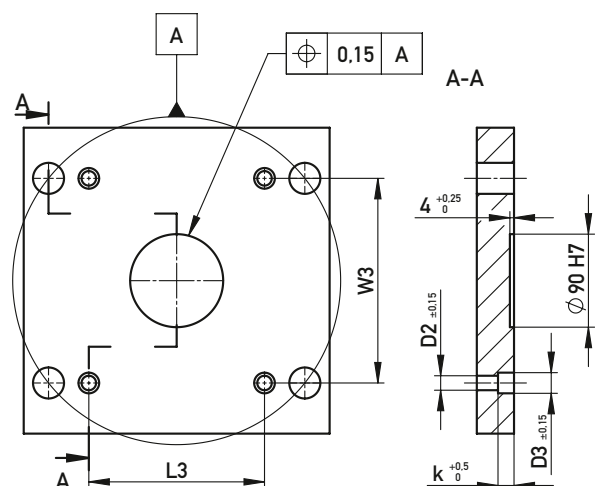

Różne rodzaje Varianta	Zakres wymiarów znamionowych Rozmezí nomální hmotnosti	Tolerancja Tolerance
L3/W3	≥ 30 ... ≤ 120	± 0,20
	> 120 ... ≤ 400	± 0,25
	> 400	± 0,35

Różne rodzaje Varianta	M10	M12	M16
D2	11	14	18
D3	18	20	26
k	13	15,5	17 (S < 36) 21 (S ≥ 36)

OTWORY PROWADZĄCE (ŚREDNICÓWKA) · VODÍČÍ VRTANÉ OTVORY (ROZTEČ)

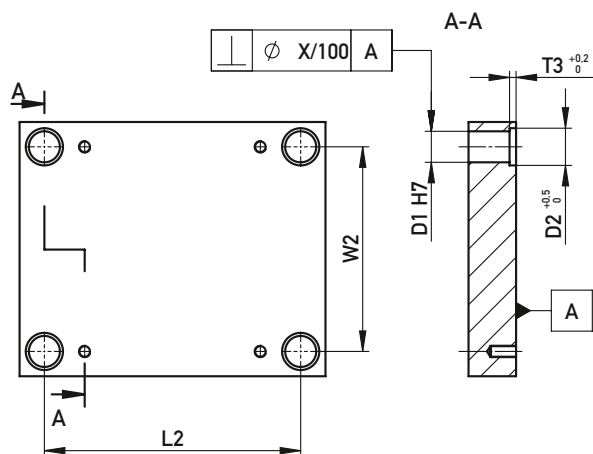

Różne rodzaje Varianta	Zakres wymiarów znamionowych Rozmezí nominální hmotnosti	Tolerancja Tolerance 10020/10030 15500/15600	Tolerancja Tolerance 10... 15...
L2/W2	≥ 90 ... ≤ 125	± 0,010	± 0,018
	> 125 ... ≤ 160	± 0,011	± 0,019
	> 160 ... ≤ 200	± 0,012	± 0,020
	> 200 ... ≤ 250	± 0,013	± 0,021
	> 250 ... ≤ 315	± 0,015	± 0,023
	> 315 ... ≤ 400	± 0,016	± 0,024
	> 400 ... ≤ 500	± 0,017	± 0,025
> 500 ... ≤ 630	± 0,019	± 0,027	

Różne rodzaje Varianta	Zakres wymiarów znamionowych Rozmezí nominální hmotnosti	Tolerancja Tolerance 10020/10030 15500/15600	Tolerancja Tolerance 10... 15...
X/100	wszystkie rozmiary všechny velikosti	0,03	0,05

LISTWA · LIŠTA

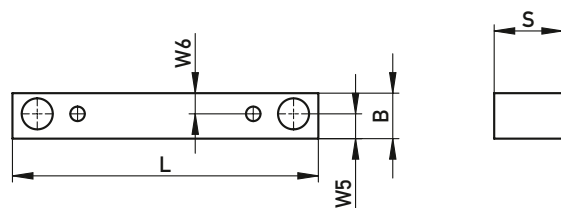

L	B	S	W5	W6
± 0,2	± 0,1	+ 0,05	± 0,1	± 0,2

PŁYTY TYPU P · P-DESKY

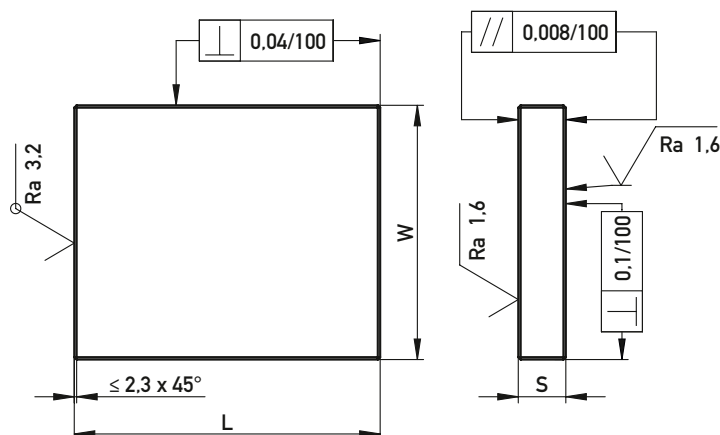

Material Materiál	L	W	S
1.1730 1.2312 Toolox[®] 33 1.2738	+ 0,5 + 0,2	+ 0,5 + 0,2	+ 0,25 + 0,15
1.2343 1.2767	+ 0,5 + 0,2	+ 0,5 + 0,2	+ 0,6 + 0,4
1.2085	+ 0,5 + 0,2	+ 0,5 + 0,2	+ 0,25 + 0,15

10000

P

B/L	156	196	246	296	346	396	446	496	546	596	646	696	796	896	996
126	•														
156	•	•	•	•											
190			•												
196		•	•	•	•	•	•	•							
216			•	•											
218			•	•											
246			•	•	•	•	•	•	•	•					
296				•	•	•	•	•	•	•	•	•			
316					•	•									
346					•	•	•	•	•	•	•	•	•		
396						•	•	•	•	•	•	•	•	•	
446							•	•	•	•	•	•	•	•	
496								•	•	•	•	•	•	•	•
546									•	•	•	•	•	•	•
596										•	•	•	•	•	•
646											•	•	•	•	•
696												•	•	•	•
796													•	•	•

11000

PX

B/L	Tolerancje/Tolerance S: +0,4/+0,6				Tolerancje/Tolerance S: +0,8/+1,0							
	346	396	446	496	546	596	646	696	796	896	996	
196	•	•	•	•								
246	•	•	•	•	•	•						
296	•	•	•	•	•	•	•	•				
316	•	•										
346	•	•	•	•	•	•	•	•	•			
396		•	•	•	•	•	•	•	•	•		
446			•	•	•	•	•	•	•	•		
496				•	•	•	•	•	•	•	•	
546					•	•	•	•	•	•	•	
596						•	•	•	•	•	•	
646							•	•	•	•	•	
696								•	•	•	•	
796									•	•	•	

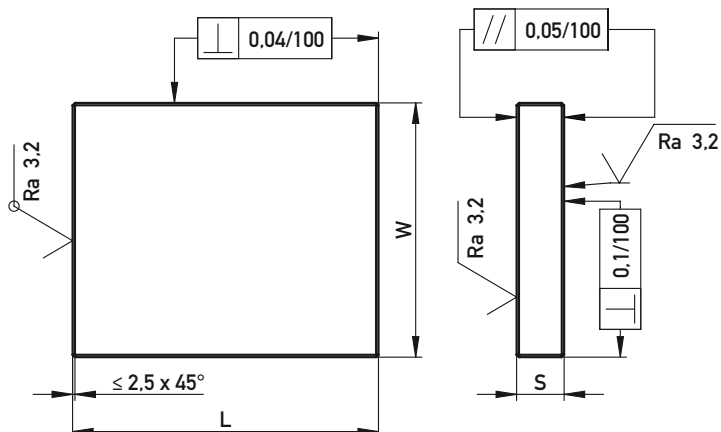

- Frezowane
 - Większy naddatek na szlifowanie
-
- Frézované
 - S přídavkem na broušení

Materiał Material	L	W
1.2312	+ 0,5 + 0,2	+ 0,5 + 0,2